



ENERGREEN[®] America
Professional Machines 

RoboEVO
EQUIPMENT

RAKE



ENERGREEN[®] America
Professional Machines 



ENERGREEN America
1242 Nowell Dr · Augusta
GA 30901 · USA
Phone CA 510 593 3144
Phone GA 706 945 2800

info@energreenamerica.com
www.energreenamerica.com



PROFESSIONAL MACHINES AND EQUIPMENT



09/2021 - © Energreen America 2021 - All rights reserved - Photo, technical and constructive characteristics subjected to modification without reporting requirement.

TECHNICAL DATA SHEET

RAKE

Tool designed to turn and air the hay that had been previously cut, in order to accelerate the process of drying, or to remove the grass from the embankments of rivers and canals. Sturdy and versatile, is fitted with two front hand levers for an easier regulation of height and direction.

Quick hydraulic couplings



Hydraulic motor



Quick attachment with pneumatic spring

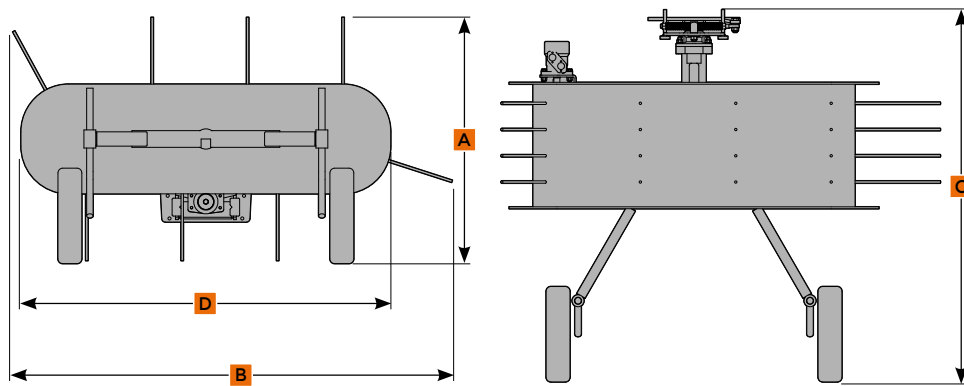

TECHNICAL DATA

(A) Height	43 in	Oscillation	+/- 13°
(B) Width	79 in	Rotation speed	220 rpm
(C) Depth	51 in	Pressure	200 bar / 2900 psi
(D) Working width	63 in	Hydraulic motor	16 hp
No. combs	10x2	Weight	278 lbs

