

ILF ATHENA 220HP



ENERGREEN[®] America

Professional Machines



SELF-PROPELLED HYDROSTATIC MACHINES



ILF SELF-PROPELLED

**SELF-PROPELLED
HYDROSTATIC MACHINES**

New



50 ft
ARM

90° ROTATING
CABIN

BRUSHCUTTER

Brushcutter Machine ideal for Road and Highway

ILF ATHENA



ILF **Athena** is a professional brushcutter machine which, thanks to its innovative technological contents, offers unparalleled performance, great flexibility and operational safety.

The machine is equipped with a 50 ft telescopic arm, where in addition to the classic mulching head, it is possible to apply several tools.

On the front side of the machine it is possible to set a PTO lifter or a DIN plate, in order to apply a front accessory that can be used simultaneously with the brush cutter arm.

STRENGTHS

ILF ATHENA



STRENGTHS



Safety and Comfort

- 90° rotating cabin homologated FOPS-ROPS
- High visibility panoramic windscreen
- Excellent working ergonomics
- SCD Stability Control Device
- Mobile ballast for the maximum extension



Quality

- 7" LCD display
- Deutz 220 HP powerful engine
- Main parts made with special steel
- EPA Tier 4f emission
- Heavy Duty hydrostatic transmission



Multifunctional

- Many tools available
- Green maintenance
- Aerial pruning and forestry work
- Winter viability
- Front and rear attachment for tools



Productivity

- 50 ft telescopic arm
- Bidirectional work
- Activity with several combined tools
- Easy and smart to use
- 360° cabin visibility





360° VISIBILITY

Complete Visibility of the Working Environment

Visibility is an essential element for a correct and safe use of the machine while working and moving.
Visibility has always been one of Energreen strengths!

ILF Athena has a comfortable and spacious cabin, equipped with a large windscreen which allows the operator to have an efficient and total view of the work, keeping a high level of comfort and physical wellness.

In terms of safety, the cabin is certified by FOPS-ROPS tests: anti-tipping, against the risk of falling objects, soundproofed, provided with an efficient cooling system, and equipped with all that features necessary to assure the operator a safe and comfortable working environment.

The 90° rotation of the cab makes the cut of the grass on both directions much easier. The rotating cabin allows the operator to always keep the correct body posture, avoiding stress and backpain or stiff neck, as well as managing the work with great comfort and care.



ROTATING CABIN



CABIN COMFORT



HOMOLOGATION
FOPS-ROPS

Maximum Safety and Comfort

ILF Athena cabin is homologated according to the FOPS-ROPS regulation that guarantees the protection against overturning and objects fall.

The cabin is completely isolated and efficiently air-conditioned thanks to a sealing system: soft gasket are settled on fixed and mobile glasses and the cabin is mounted on elastic supports on sustain points.

In this way, this multifunction machine is suited for working in dusty and noisy environments for many hours per day, still keeping a high level of comfort.

The cabin is available in three versions:
STANDARD - COMFORT - PRESTIGE



CABIN STANDARD

- 90° rotating cabin
- FOPS-ROPS homologated cabin
- 7" LCD display
- Tilting and height-adjustable steering column
- Electronic direction control lever
- Adjustable armrest with Joystick
- Front windshield washer wiper
- Air conditioning with anti-pollen filter
- Left mirror
- Height-adjustable LED beacon
- Cabin door partially openable
- Darked anti-UV rear window, partially openable
- Lateral documents holder
- Automatic LED courtesy lights
- Emergency glass break hammer
- External electrical socket for 12 V services
- Internal 12 V DC socket
- Two-way USB socket
- Clothes hangers
- GRAMMER MAXIMO XXL seat with air suspension and adjustable lumbar shock absorber



CABIN COMFORT

IN ADDITION TO THE «STANDARD CABIN» INSTALLATION

- Cruise Control
- Instant reverse pedal
- DAB/Bluetooth stereo
- LED working lights
- Retractable sunshade on front windshield



CABIN PRESTIGE

IN ADDITION TO THE «COMFORT CABIN» INSTALLATION

- Display with one camera
- Twin LED beacon
- Porthole with grille, curtain and windscreen wiper.
- Windshield wiper on the right side.
- 2 kg fire extinguisher
- GRAMMER MAXIMO EVOLUTION DYNAMIC seat with larger seat dimensions, air suspension system, longitudinal shock absorber, side suspension, lumbar shock absorber and active climate control system



ADJUSTABLE STEERING WHEEL



MONITOR SCREEN WITH CAMERA



TOP PORTHOLE WITH GRILLE



F15

ILF Athena is equipped with a solid telescopic arm designed to work with an extension range up to 50 ft, both in depth and in height. The special design underlines its qualities for working along the routes, even where there are security barriers up to 3 ft. The telescopic extension allows to easily reach even the furthest and narrowest areas for operating on the green maintenance always keeping the performance at the top.

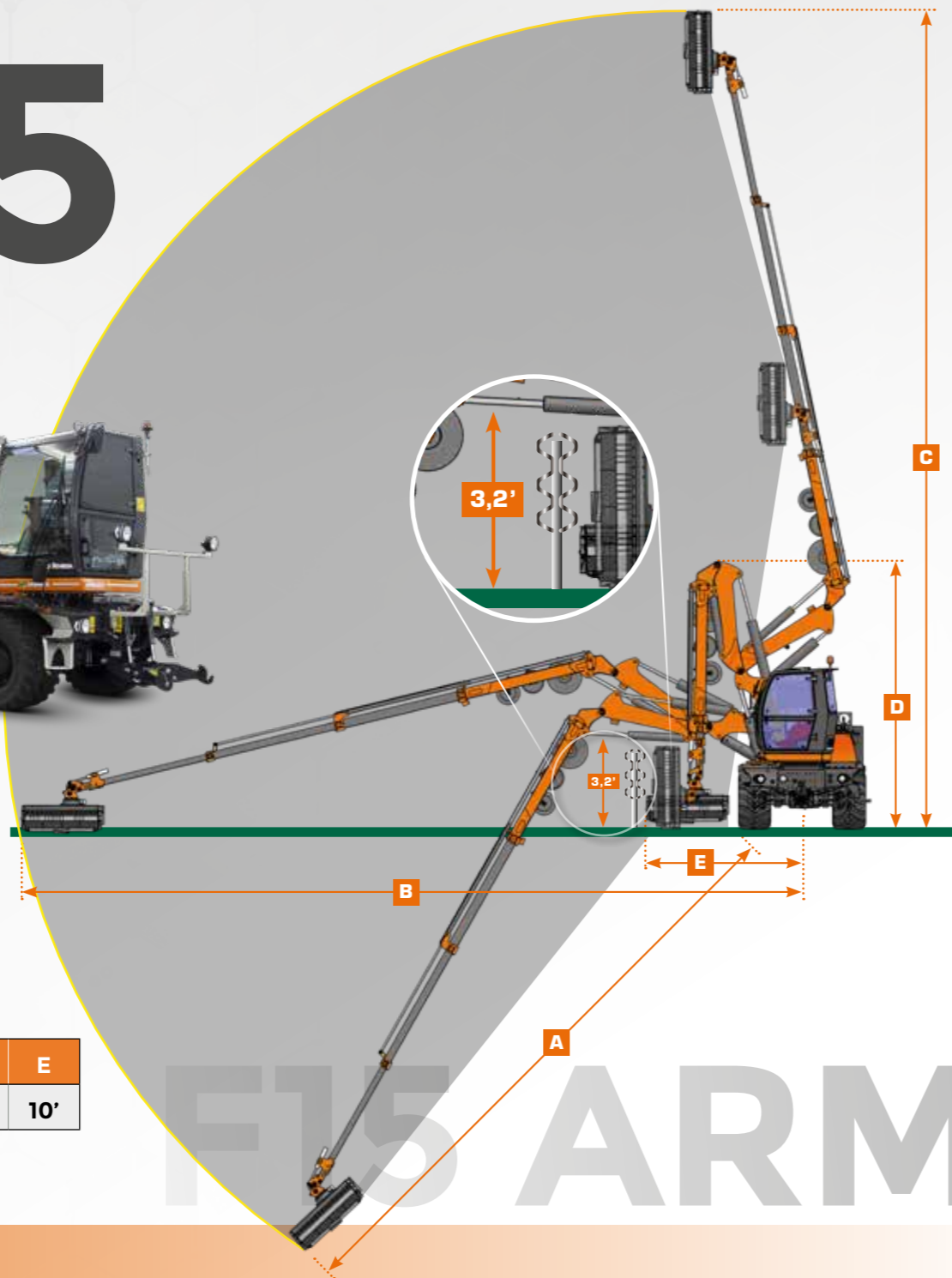

A	B	C	D	E
41'	50'	50,5'	16'	10'

(feet)

F15 ARM





AERIAL MAINTENANCE



Aerial Maintenance

ILF **Athena** is the perfect machine for every type of aerial pruning. The strong 50 ft telescopic arm, equipped with professional tools such as cutter discs bars, power shears and pruning scissors allows an easy aerial maintenance even at great heights.





ACCESSORIES

A FRONT ATTACHMENT



LIFTER "HERCULES" (10 T.)
(optional)

DIN PLATE 76060
(optional)

B REAR ATTACHMENT



BLOWER
(optional)

TOW HOOK

EQUIPMENT

THE SUITABLE TOOL FOR EVERY WORK

<p>C</p> <p>NEW SPEED 47" CUTTING HEAD</p>	<p>NEW SPEED 59" CUTTING HEAD</p>	<p>CONVEYOR HEAD CUTTING HEAD WITH CONVEYOR BELT</p>	<p>FORESTRY HEAD FORESTRY HEAD WITH FIXED TEETH</p>	<p>A</p> <p>RAIBER BARRIER MOWER</p> <p>TRANSFORMER 840</p>
<p>SAW BAR CUTTER DISCS BAR</p>	<p>CUTTER BAR</p>	<p>POWER SHEARS</p>	<p>IRON BRUSH</p>	<p>DISCOVERY 840</p>
<p>DITCH CLEANER</p>	<p>ORANGE PEEL GRAPPLE</p>	<p>TRUNK PINCERS</p>	<p>FORC-ONE</p>	<p>ROTATOR UNIT ROTATOR UNIT FOR 180° EQUIPMENT ROTATION</p>
<p>EXTRA TRUNK PRUNING SCISSORS-PINCERS</p>	<p>STUMP GRINDER</p>	<p>Only for the telescopic arm 3P</p> <p>RIVER BUCKET WEEDING-MOWING BUCKET</p>	<p>DITCH BUCKET</p>	

EQUIPMENT

AGILITY

Agility and Accuracy in the Movements



RADIUS
10 FT

The polyvalent soul of this machine is highlighted also from the 4-wheel drive traction system, all steering, hydraulically configurable from the cab control in 3 different operating modes:

- **2 front steering wheels**, for the maximum agility on road movement.
- **4 steering wheels**, a system that halves the turning range of the machine, ideal for working in narrow areas.
- **4 parallel steering wheels (crab)**, useful for moving special tools or for moving away from an obstacle.

2 STEERING WHEELS



4 STEERING WHEELS CONCENTRIC



4 STEERING WHEELS PARALLEL



STABILITY

SCD Stability Control Device

The SCD Stability Control Device allows to lock the front axle oscillation, increasing the stability of the machine, in order to guarantee the maximum level of performance and safety for the operator. This plus is composed by two hydraulic jacks fixed on the chassis of the machine and controlled by the operator inside the cab.

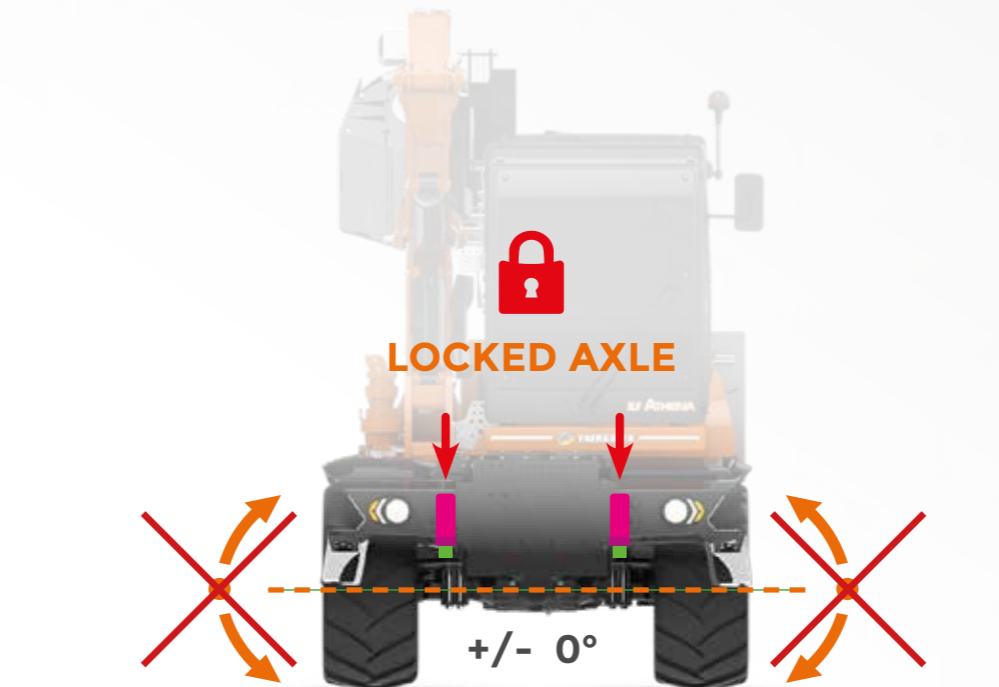
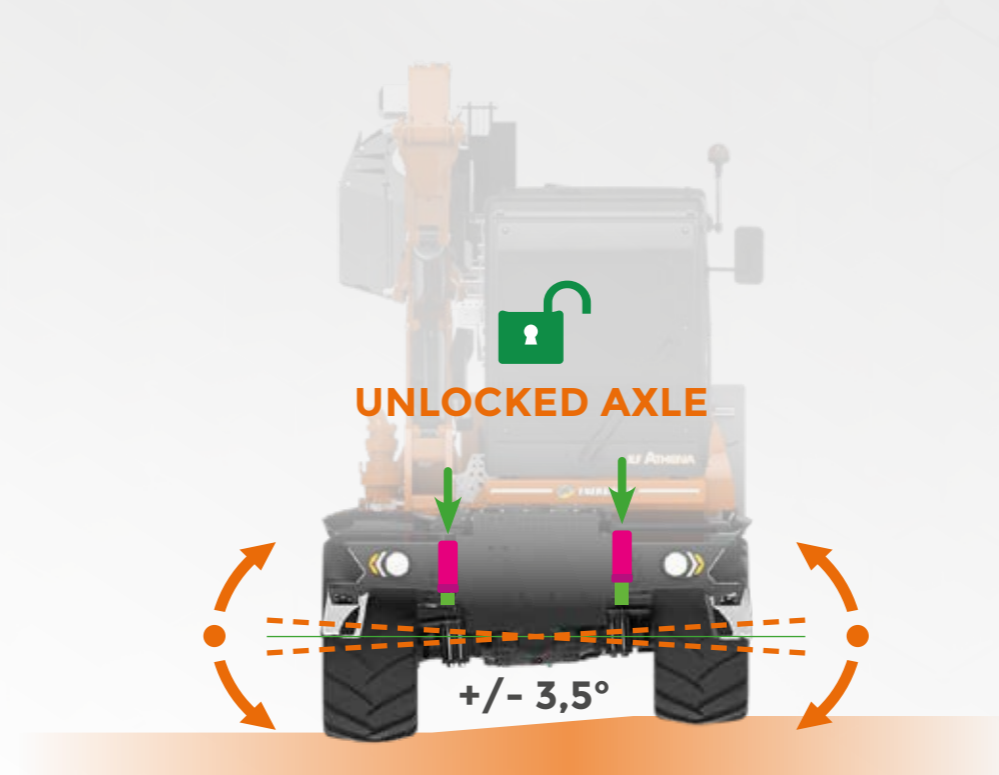

OPTIONAL



AUTO LUBE Automatic greasing system

The **AUTO LUBE** system is built with an electric greasing pump, electronically controlled, that allows to work independently and to be programmed to ensure the best lubrication of pins and bushing of the arm and of hydraulic cylinders. Moreover, this system allows an important reduction of maintenance hours.



JOYSTICK Simple and intuitive

High quality joystick with proportional main controls that allows a precise and smooth control of the equipments. It allows you to move up to 3 arm functions at the same time with an excellent gradual movement.

TYRES



WIDE RANGE
OF TIRES
FOR EVERY TYPE
OF GROUND
AND WORK

STANDARD

MICHELIN
445/70
R 22.5



FOR
ON-ROAD
AND
OFF-ROAD
ACTIVITY

OPTION A

TRELLEBORG
650/45
R 22.5



IDEAL FOR
OFF-ROAD
ACTIVITY,
RADIAL TIRE

OPTION B

ALLIANCE
315/80
R 22.5
DUAL



IDEAL FOR
ON ROAD
ACTIVITY

ENGINE

ILF ATHENA

DEUTZ Power Engine



ILF Athena is equipped with a Deutz 6.1 220 HP (160 kW) 6-cylinder inline engine with liquid-cooled, external exhaust gas recirculation and EPA Tier 4f emissions.

The powerful DEUTZ Common Rail injection system with high pressure with 2 valves per cylinder and the electronic engine control (EMR) with intelligent link to the drive management ensure optimum engine performance at low fuel consumption.

- Minimum consumption of operative liquids compared to competitors.
- Technical support and diagnosis provided by DEUTZ's worldwide service network.



THE ENGINE COMPARTMENT IS EASILY ACCESSIBLE FOR MAINTENANCE



FIVE INDEPENDENT HYDRAULIC SYSTEMS:
1. MOVEMENT
2. CUTTING HEAD
3. STEERING
4. BRAKING
5. ARM FUNCTIONS

INLET HIGH PRESSURE FILTER TO THE DISTRIBUTOR

OSCILLATING FRONT AXLE

JACK FOR OSCILLATION CONTROL

FIXED REAR AXLE

HD-FRAME IN STRENX®

4 WHEEL DRIVE

HYDROSTATIC TRANSMISSION

NEGATIVE PARKING BRAKE (REAR AXLE)

100% FRONT AND REAR DIFFERENTIAL LOCKING

BRAKE DISCS IN OIL BATH ON BOTH AXLES

QUALITY

DEUTZ 6.1



Adjustable steering column



Two-seater cabin



Power track



Proportional distributor Joystick



Steering wheel with multifunction display



Deutz 6.1 220 HP EPA Tier 4f engine



FLEXXAIRE® self-cleaning reversible fan



Integrated step

CABIN

Cabin	Rotating un to 90°
Multifunction display	Steering wheel integrated
Steering wheel	Adjustable
Joystick	Electronic
Rotary lamp	Switch inside the cabin
Air conditioning	Electronic
Rear glasses	Darkened anti UV
Cabin door	Openable 60 - 40
Adjustable seat	Air suspension
Power socket	12 V
Battery switch	Automatic
Cabin homologation	FOPS-ROPS

ENGINE

Brand	Deutz 6.1
Type	6 Cylinders Diesel
Power	220 hp (160 kW)
Injection	Common Rail DCR
Emissions	EPA Tier 4f
Alternator	150 A
Pre-heating air engine intake	
Air intercooler radiator	
Computer for visualization engine data	
Self-cleaning reversible fan	FLEXXAIRE
Fuel tank capacity	83 gal
AdBlue capacity	8 gal

HYDRAULIC SYSTEM

Pumps and motors in closed circuits	
Cutting head pump	Piston
Translation pump	Piston
Pumps and motors in open circuits	
Arm movement (LS)	Piston
Brakes system	Gear
Steering system	Gear
Hydraulic distributor	Electronic and proportional
Oil flow for attachment	42 gal/min
Oil pressure for attachment	290 bar

TRASMISSION AND BRAKES

Transmission	Hydrostatic
Traction	4 x 4 (disengageable)
Speed variation	0 - 24 mph (continuous)
Manual gearbox	2 gears
Wheel alignment	Electronic
Front axle	Oscillating
Front axle block	Hydraulic
Steering axles	2 axles
Axle block	Front 100%
	Rear 100%
Parking brake	Negative
Service brakes	6 discs for axle

DIMENSIONS AND WEIGHT

A Length	231 in
B Height	155 in
C Width	100 in
D Wheelbase	110 in
Machine weight without equipment	40000 lb
Cutting head (59") + rotator unit weight	1000 lb

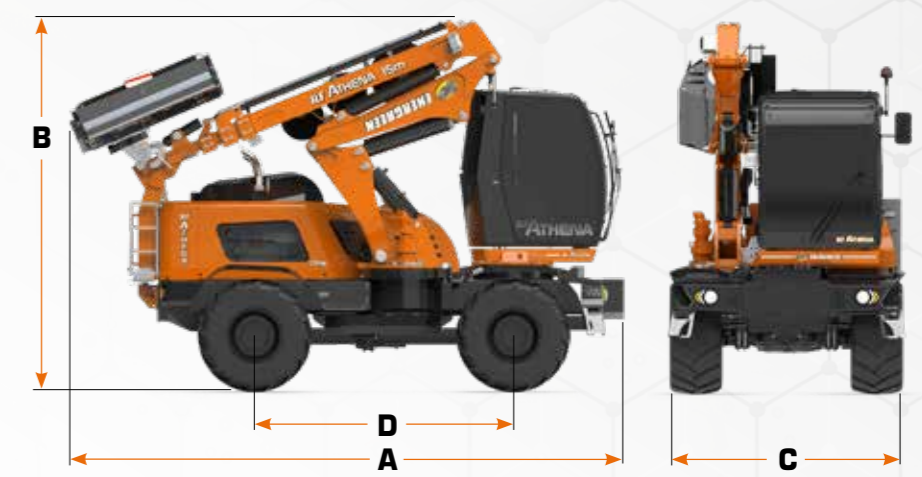

OPTIONAL



Led working light kit



Cabin porthole



Reverse gear camera



Moving ballast with step

Technical and construction specifications may be subject to change without prior notice.



ILF ATHENA

ENERGREENAMERICA.COM



SELF-PROPELLED HYDROSTATIC MACHINES



Local dealership



ENERGREEN[®] *America*
Professional Machines

ENERGREEN America · 1242 Nowell Dr · Augusta · GA 30901 · USA
Phone CA 510 593 3144 · Phone GA 706 945 2800
info@energgreenamerica.com · www.energgreenamerica.com

PROFESSIONAL MACHINES AND EQUIPMENT



ELUSDPI500100 - 06/21 - © Energreen America 2021 - All rights reserved
Photo, technical and constructive characteristics subjected to modification without reporting requirement.